



3 Frame Plunger Pump

**Stainless
Steel
Models**

231, 241, 271

**Nickel Aluminum
Bronze
Models**

237, 247, 277

FEATURES

Superior Design

- Triplex plunger design gives smoother liquid flow.
- Hi-Pressure Seals are completely lubricated and cooled by the liquid being pumped.
- Inlet and discharge valve assemblies interchange for easier maintenance.
- Lubricated Lo-Pressure Seals provides double protection against external leakage.
- Oil bath crankcase assures optimum lubrication.
- Close tolerance concentricity of the ceramic plunger maximizes seal life.
- Optional Belt Drive or Motorized versions offer system flexibility.

Quality Materials

- Precision design 316 stainless steel valves and seats are hardened and polished for ultimate seating and extended valve life.
- 316 Stainless Steel or Nickel Aluminum Bronze manifolds are strong and corrosion resistant.
- Special concentric, high-density, polished, solid ceramic plungers provide a true wear surface and extended seal life.
- Specially formulated, CAT PUMP exclusive, Hi-Pressure Seals offer unmatched performance and seal life.
- Die cast aluminum crankcase provides high strength, minimum weight and precision tolerance control.
- Chrome-moly crankshaft gives unmatched strength and surface hardness.
- Oversized crankshaft bearings with greater capacity mean longer bearing life.

Easy Maintenance

- Wet-end is easily serviced without entering crankcase, requiring less time and effort.
- Preset packings mean no packing gland adjustment is necessary, reducing maintenance costs.

⚠ WARNING

All systems require both a primary pressure regulating device (i.e., regulator, unloader) and a secondary pressure safety relief device (i.e., pop-off valve, safety valve). Failure to install such relief devices could result in personal injury or damage to the pump or to system components. CAT PUMPS does not assume any liability or responsibility for the operation of a customer's high pressure system.

SPECIFICATIONS

U.S. Measure

Metric Measure

MODELS 231 AND 237

Flow	2.3 GPM	(8.7 L/M)
Pressure Range	100 to 1500 PSI	(7 to 105 BAR)
RPM	1725 RPM	(1725 RPM)
Stroke	0.276"	(7 mm)

MODELS 241 AND 247

Flow	3.6 GPM	(13.6 L/M)
Pressure Range	100 to 1200 PSI	(7 to 85 BAR)
RPM	1725 RPM	(1725 RPM)
Stroke	0.433"	(11 mm)

MODELS 271 AND 277

Flow	3.5 GPM	(13.2 L/M)
Pressure Range	100 to 1500 PSI	(7 to 105 BAR)
RPM	1450 RPM	(1450 RPM)
Stroke	0.500"	(12.7 mm)

COMMON SPECIFICATIONS

Bore	0.709"	(18 mm)
Inlet Pressure Range	Flooded to 60 PSI	(Flooded to 4 BAR)
Crankcase Capacity	15 oz.	(.45 L)
Maximum Liquid Temperature	160°F	(71°C)
Above 130°F call CAT PUMPS for inlet conditions and elastomer recommendations.		
Inlet Ports (2)	1/2" NPTF	(1/2" NPTF)
Discharge Ports (2)	3/8" NPTF	(3/8" NPTF)
Pulley Mounting	Either Side	(Either Side)
Shaft Diameter	0.650"	(16.5 mm)
Weight	13.4 lbs.	(6.1 kg)
Dimensions	10.24 x 8.78 x 5.35"	(260 x 223 x 136 mm)

ELECTRIC HORSEPOWER REQUIREMENTS

MODEL	FLOW		PRESSURE			MOTOR PULLEY SIZE	
	U.S. GPM	L/M	PSI	PSI	PSI	Using 1725 RPM Motor & Std. 5.0" Pump Pulley O.D.	
			1000 BAR 70	1200 BAR 85	1500 BAR 105	RPM	Pulley O.D.
271, 277	3.5	13.2	2.4	2.9	3.6	1450	4.1
	3.0	11.4	2.1	2.5	3.1	1240	3.5
231, 237	2.3	8.7	1.6	1.9	2.4	1725	Direct Drive
241, 247	3.6	13.6	2.5	3.0	N/A	1725	Direct Drive

DETERMINING THE PUMP R.P.M. $\frac{\text{Rated G.P.M.}}{\text{Rated R.P.M.}}$ = "Desired" G.P.M. / "Desired" R.P.M.

DETERMINING THE REQUIRED H.P. $\frac{\text{GPM} \times \text{PSI}}{1460}$ = Electric Brake / H. P. Required

DETERMINING MOTOR PULLEY SIZE $\frac{\text{Motor Pulley O.D.}}{\text{Pump R.P.M.}}$ = $\frac{\text{Pump Pulley O.D.}}{\text{Motor R.P.M.}}$

See complete Drive Packages [Incls: Pulleys, Belts, Hubs, Key] Tech Bulletin 003.
Refer to pump **Service Manual** for repair procedure, additional technical information and **pump warranty**.

"Customer confidence is our greatest asset"

PARTS LIST

ITEM	PART NUMBER		DESCRIPTION	QTY
	231	237		
	241	247		
	271 MATL	277 MATL		
2	30047 <i>STL</i>	30047 <i>STL</i>	Key (M5x5x24)	1
5	92538 S	92538 S	Screw, Sems HHC (M6x16)	8
8	27950 AL	27950 AL	Cover, Bearing	2
10	26536 NBR	26536 NBR	O-Ring, Bearing Cover - 70D	2
11	24159 NBR	24159 NBR	Seal, Oil	2
15	14487 <i>STL</i>	14487 <i>STL</i>	Bearing, Ball	2
20	48867 TNM	48867 TNM	Rod, Connecting Assy	3
25	46946 FCM	46946 FCM	Crankshaft, Dual End - 231, 237 (M7)	1
	46951 FCM	46951 FCM	Crankshaft, Dual End - 241, 247 (M11)	1
	108062 FCM	108062 FCM	Crankshaft, Dual End - 271, 277 (M12.7)	1
31	828710 —	828710 —	Protector, Oil Cap w/Foam Gasket	1
32	43211 ABS	43211 ABS	Cap, Oil Filler	1
33	14177 NBR	14177 NBR	O-Ring, Oil Filler Cap - 70D	1
37	92241 —	92241 —	Gauge, Oil Bubble w/Gasket - 80D	1
38	44428 NBR	44428 NBR	Gasket, Flat, Oil Gauge - 80D	1
40	92542 S	92542 S	Screw, Sems HHC (M6x20)	6
48	25625 STCP	25625 STCP	Plug, Drain (1/4"x19BSP)	1
49	23170 NBR	23170 NBR	O-Ring, Drain Plug - 70D	1
50	43339 AL	43339 AL	Cover, Rear	1
51	43340 NBR	43340 NBR	O-Ring, Rear Cover	1
53	44789 AL	44789 AL	Crankcase, [07/05]	1
64	16948 CM	16948 CM	Pin, Crosshead	3
65	45114 SSZZ	45114 SSZZ	Rod, Plunger	3
69	20017 STZP	20017 STZP	Washer, Oil Seal	3
	126259 <i>STCP R</i>	126259 <i>STCP R</i>	Washer, Oil (M24)	3
70	25301 NBR	25301 NBR	Seal, Oil - 80D	3
71	26854 STZP	26854 STZP	Washer, Oil Seal	3
	126189 <i>STCP R</i>	126189 <i>STCP R</i>	Washer, Oil Seal	3
75	43900 S	43900 S	Slinger, Barrier	3
88	45697 S	45697 S	Washer, Keyhole (M18)	3
90	43901 CC	43901 CC	Plunger (M18x43)	3
95	126550 STCP R	126550 STCP R	Stud, Plunger Retainer (M6x43)	3
96	43235 PTFE	43235 PTFE	Back-up-Ring, Plunger Retainer	3
97	17399 NBR	17399 NBR	O-Ring, Plunger Retainer - 80D	3
	14160 <i>FPM</i>	14160 <i>FPM</i>	O-Ring, Plunger Retainer - 70D	3
	◆ 46204 <i>EPDM</i>	◆ 46204 <i>EPDM</i>	O-Ring, Plunger Retainer - 70D	3
98	44041 SS	44041 SS	Gasket, Plunger Retainer (M12.5)	3
99	44031 SS	44031 SS	Retainer, Plunger (M6)	3
100	28597 PVDF	28597 PVDF	Retainer, Seal	3
106	44053 NBR	44053 NBR	Seal, LPS w/SS-Spg	3
	44926 <i>FPM</i>	44926 <i>FPM</i>	Seal, LPS w/SS-Spg	3
	◆ 46651 <i>EPDM</i>	◆ 46651 <i>EPDM</i>	Seal, LPS w/SS-Spg	3
110	◆ 46425 SS	◆ 44052 NAB	Manifold, Inlet	1
116	15847 S	15847 S	Lockwasher (M10)	2
117	87950 S	87950 S	Screw, HSH (M10x35)	2
125	44652 SNG	44652 SNG	Seal, HPS w/SS	3
	44925 <i>FPM</i>	44925 <i>FPM</i>	Seal, HPS w/SS	3
	46652 <i>HT*</i>	46652 <i>HT*</i>	Seal, HPS w/SS,2-Pc w/S - support	3
139	◆ 45156 SS	◆ 44563 NAB	Plug, Inlet (1/2" NPT)	1
143	17547 NBR	17547 NBR	O-Ring, Inlet Valve Adapter, Rear - 85D	3
	11685 <i>FPM</i>	11685 <i>FPM</i>	O-Ring, Inlet Valve Adapter, Rear - 85D	3
	◆ 46648 <i>EPDM</i>	◆ 46648 <i>EPDM</i>	O-Ring, Inlet Valve Adapter, Rear - 70D	3
150	44060 SS	44060 SS	Adapter, Inlet Valve	3
154	43893 NBR	43893 NBR	O-Ring, Inlet Valve Adapter, Front - 80D	3
	44927 <i>FPM</i>	44927 <i>FPM</i>	O-Ring, Inlet Valve Adapter, Front	3
	◆ 46649 <i>EPDM</i>	◆ 46649 <i>EPDM</i>	O-Ring, Inlet Valve Adapter, Front - 80D	3
155	26089 NBR	26089 NBR	O-Ring, Discharge Valve Adapter, Rear - 80D	3
	11377 <i>FPM</i>	11377 <i>FPM</i>	O-Ring, Discharge Valve Adapter, Rear - 80D	3
	◆ 46647 <i>EPDM</i>	◆ 46647 <i>EPDM</i>	O-Ring, Discharge Valve Adapter, Rear - 80D	3
157	44059 SS	44059 SS	Adapter, Discharge Valve	3
159	26089 NBR	26089 NBR	O-Ring, Discharge Valve Adapter, Front - 80D	3
	11377 <i>FPM</i>	11377 <i>FPM</i>	O-Ring, Discharge Valve Adapter, Front - 80D	3
	◆ 46647 <i>EPDM</i>	◆ 46647 <i>EPDM</i>	O-Ring, Discharge Valve Adapter, Front - 80D	3
164	44058 SS	44058 SS	Seat	6
165	44001 NBR	44001 NBR	O-Ring, Seat - 80D	6
	44928 <i>FPM</i>	44928 <i>FPM</i>	O-Ring, Seat - 80D	6
	◆ 46650 <i>EPDM</i>	◆ 46650 <i>EPDM</i>	O-Ring, Seat - 80D	6
166	44057 SS	44057 SS	Valve	6
167	44056 SS	44056 SS	Spring	6
168	44055 SS	44055 SS	Retainer, Spring	6
185	◆ 46427 SS	◆ 44054 NAB	Manifold, Discharge	1
186	15847 S	15847 S	Lockwasher (M10)	4
188	87952 S	87952 S	Screw, HSH (M10x55)	4
250	25130 <i>STCP</i>	25130 <i>STCP</i>	Protector, Shaft	1
260	30612 <i>STZP</i>	30612 <i>STZP</i>	Rail, Angle Assy (Incls: 26246,30901,30910,30920)	1
265	30651 —	30651 —	Kit, Complete Mounting (30612,30246,25130)	1
270	30246 <i>STL</i>	30246 <i>STL</i>	Pulley & Key Assy (Incls: 30032,30047) [See Drive Packages, Tech Bulletin 003]	1
277	34121 AL	34121 AL	Bell Housing Assy (56C, 2.0 Hp)	1
	34126 AL	34126 AL	Bell Housing Assy (182TC-184TC, 3.0 Hp)	1
278	8215 AL	8215 AL	Flexible Coupling Assy (M16.5 to 5/8")	1
	8220 AL	8220 AL	Flexible Coupling Assy (M16.5 to 1-1/8")	1
283	34334 —	34334 —	Kit, Oil Drain	1

EXPLODED VIEW

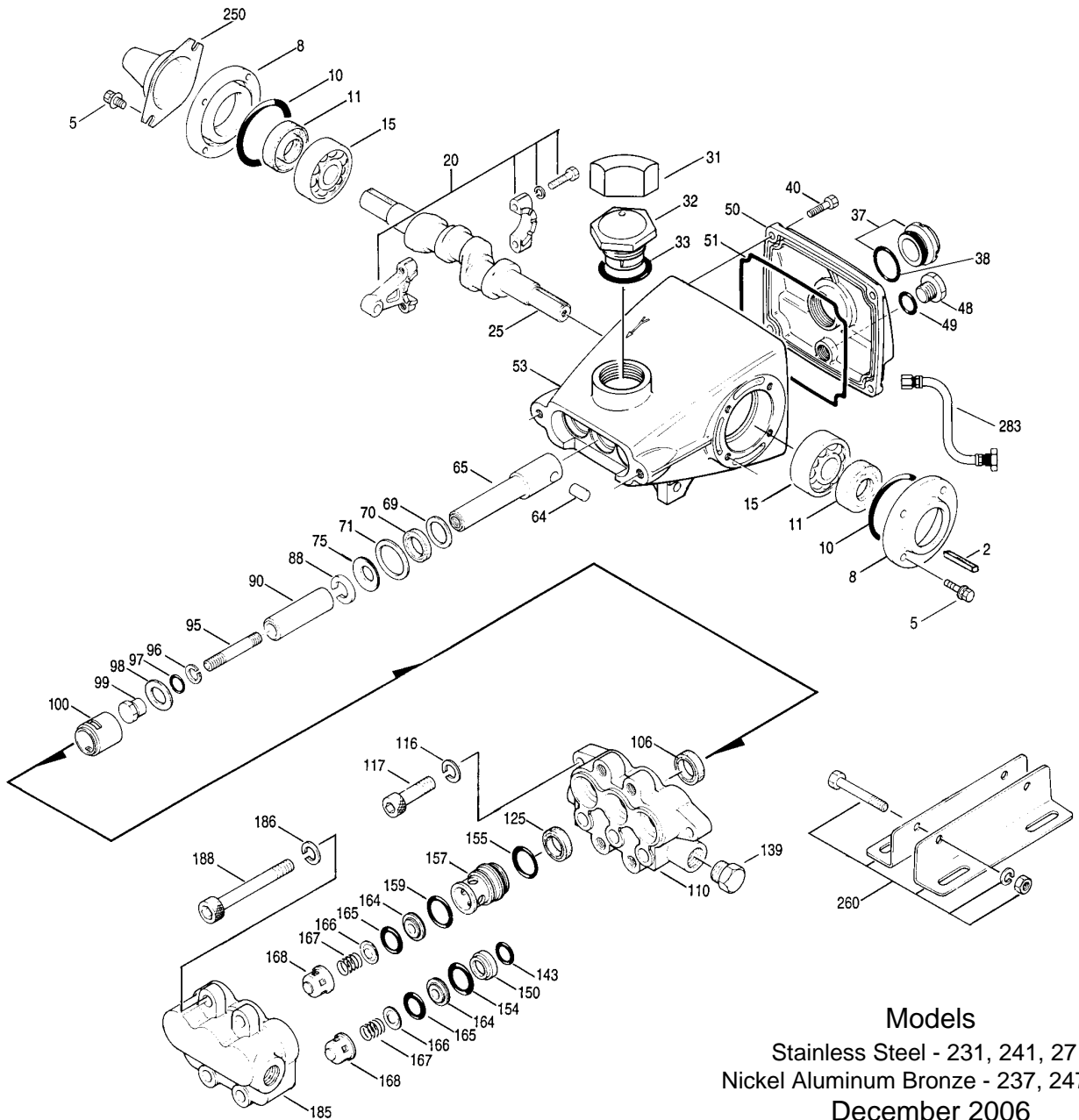

Models
 Stainless Steel - 231, 241, 271
 Nickel Aluminum Bronze - 237, 247, 277
 December 2006

	231	241	271	MATL	237	247	277	MATL		
290	6124	—	6124	—	<i>Liquid Gasket (3 oz.)</i>					1
299	814823	SS	815262	NAB	<i>Head, Complete</i>					1
300	30983	<i>NBR</i>	30983	<i>NBR</i>	<i>Kit, Seal (Incls: 97,106,125,143,154,155,159,165)</i>					1
	33609	<i>FPM</i>	33609	<i>FPM</i>	<i>Kit, Seal (Incls: 97,106,125,143,154,155,159,165)</i>					1
	◆ 33914	<i>EPDM*</i>	◆ 33914	<i>EPDM*</i>	<i>Kit, Seal (Incls: 97,106,125,143,154,155,159,165)</i>					1
	33915	<i>HT</i>	33915	<i>HT</i>	<i>Kit, Seal, Hi Temp (Incls: 97,106,125,143,154,155,159,165)</i>					1
310	30982	<i>NBR</i>	30982	<i>NBR</i>	<i>Kit, Valve (Incls: 143,154,155,164,165,166,167,168)</i>					1
	31216	<i>FPM</i>	31216	<i>FPM</i>	<i>Kit, Valve (Incls: 143,154,155,164,165,166,167,168)</i>					1
	◆ 31217	<i>EPDM</i>	◆ 31217	<i>EPDM</i>	<i>Kit, Valve (Incls: 143,154,155,164,165,166,167,168)</i>					1
350	30696	<i>STZP</i>	30696	<i>STZP</i>	<i>Pliers, Reverse</i>					1
390	711500	—	711500	—	<i>C.A.T. (For R.O. or Industrial Applications)</i>					1
391	711502	—	711502	—	<i>Adapter (2 per C.A.T.) (See Data Sheet for complete selection)</i>					2
—	6575	—	6575	—	<i>Plunger Pump Service DVD</i>					1
—	6107	—	6107	—	<i>Oil, Bottle (21 oz.) ISO 68 Multi-viscosity Hydraulic</i>					1
					<i>(Fill to specified crankcase capacity prior to start-up)</i>					

Bold print part numbers are unique to a particular pump model. Italics are optional items. ◆ Silicone oil/grease required.
 R components comply with RoHS Directive. *Review material codes for individual items (HT generally may be used as alternate).
 See Tech Bulletins 002, 003, 008, 024, 033, 034, 036, 043, 047, 049, 052, 053, 067, 073, 074, 077 and 083 for additional information.

C.A.T. highly recommended for pressurized inlet, R.O. and Industrial applications.

MATERIAL CODES (Not Part of Part Number): ABS=ABS Plastic AL=Aluminum CC=Ceramic CM=Chrome-Moly
 EPDM=Ethylene Propylene Diene Monomer FCM=Forged Chrome-moly FPM=Fluorocarbon HT=Hi-Temp (EPDM Alternative) NAB=Nickel Aluminum Bronze
 NBR=Medium Nitrile (Buna-N) PTFE=Pure Polytetrafluoroethylene PVDF=Polyvinylidene Fluoride S=304SS SS=316SS SNG=Special Blend (Buna)
 SSZZ=316SS/Zamak STCP=Steel/Chrome Plated STL=Steel STZP=Steel/Zinc Plated TNM= Special High-Strength

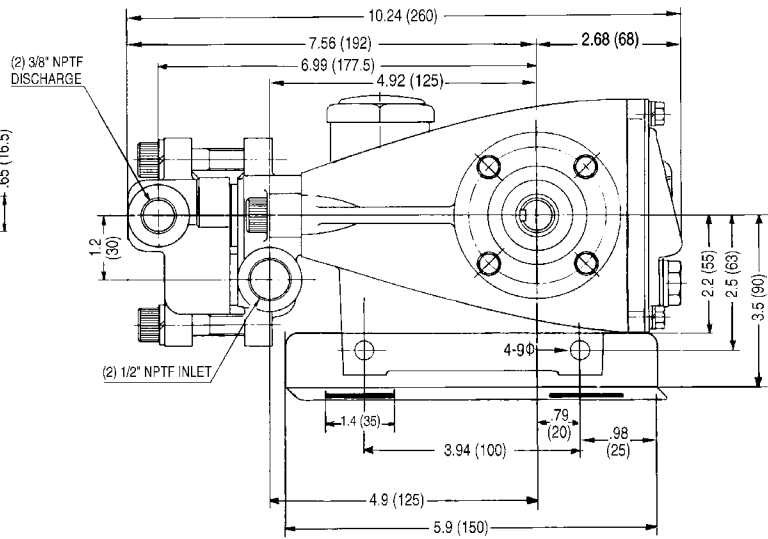
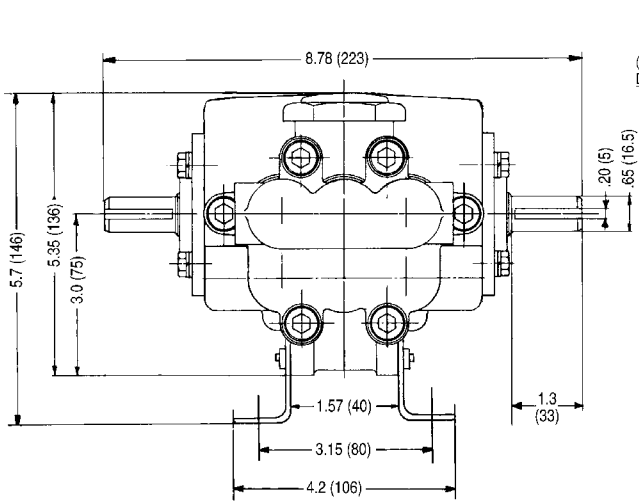

Models 231, 241, 271, 237, 247, 277

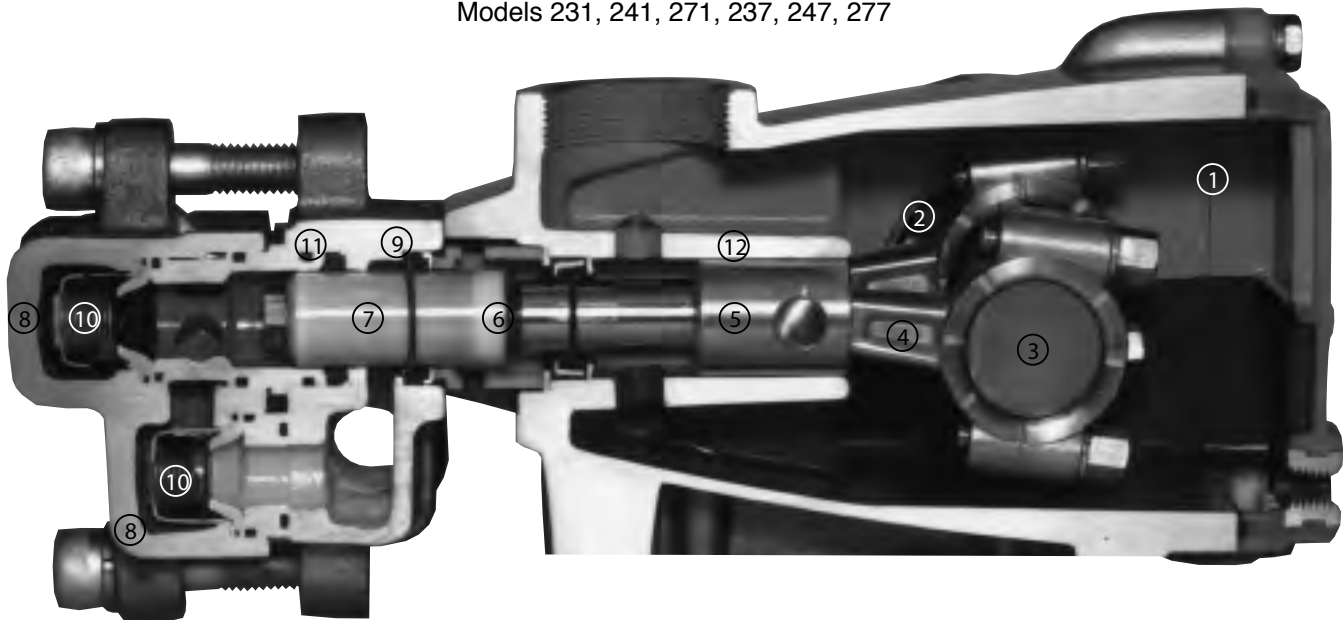

- 1 Die cast aluminum **crankcase** means high strength, lightweight, and excellent tolerance control.
- 2 Oversized crankshaft **bearings** provide extended bearing life and pump performance.
- 3 Chrome-moly **crankshaft** provides unmatched strength and surface hardness for long life.
- 4 Matched oversized TNM **connecting rods** noted for superior tensile strength and bearing quality.
- 5 The **plunger rods** are high tensile strength stainless steel with Zamak crossheads.
- 6 The stainless steel **slinger** provides back-up protection for the crankcase seal, keeping pumped liquids out of the crankcase.
- 7 Special concentric, high density, polished, solid ceramic **plungers** provide a true wear surface and extended seal life
- 8 **Manifolds** are a high tensile strength 316 stainless steel or nickel aluminum bronze for long term, continuous duty.
- 9 100% wet **seal** design adds to service life by allowing pumped liquids to cool and lubricate on both sides.
- 10 Stainless steel **valves, seats and springs** provide corrosion-resistance, ultimate seating and extended life.
- 11 Specially formulated, CAT PUMP exclusive, **Hi-Pressure Seals** offer unmatched performance and seal life.
- 12 **Crossheads** are 360° supported for uncompromising alignment.

Products described hereon are covered by one or more of the following U.S. patents 3558244, 3652188, 3809508, 3920356, 3930756 and 5035580



Octo Marine
 12 Cite Artisanale de Valbonne,
 108 Chemin de St Helene,
 06560 Valbonne, France
 Tel. +33(0) 493 650 484, Fax. +33(0) 493 655 832
 octomarine@wanadoo.fr